

Syntheses, Rate Constants, and X-ray Structures of Alkylrhodioximes with σ -Donating Alkyl Groups Me, Et, and *i*-Pr. A Comparison with the Analogous Alkylcobaloximes, a Vitamin B₁₂ Model

Nevenka Bresciani Pahor, Renata Dreos-Garlatti, Silvano Geremia, Lucio Randaccio,*
Giovanni Tazher, and Ennio Zangrando

Received November 29, 1989

The syntheses, the X-ray structures, and kinetic measurements of $\text{pyRh}(\text{DH})_2\text{R}$ complexes, where py = pyridine, DH = monoanion of dimethylglyoxime, and R = methyl (I), ethyl (II), and isopropyl (III), are reported. Crystallographic details follow. I: $\text{RhO}_4\text{N}_3\text{C}_{14}\text{H}_{22}^{1/4}\text{H}_2\text{O}$, orthorhombic, $P2_12_12$, $a = 16.400$ (3) Å, $b = 11.963$ (3) Å, $c = 9.329$ (2) Å, $D(\text{calcd}) = 1.55$ g cm^{-3} , $Z = 4$, $R(F_o) = 0.031$ for 2610 independent reflections. II: $\text{RhO}_4\text{N}_3\text{C}_{15}\text{H}_{24}$, triclinic, $P\bar{1}$, $a = 9.140$ (3) Å, $b = 12.120$ (4) Å, $c = 16.744$ (6) Å, $\alpha = 98.53$ (2)°, $\beta = 90.30$ (2)°, $\gamma = 92.09$ (2)°, $D(\text{calcd}) = 1.60$ g cm^{-3} , $Z = 4$, $R(F_o) = 0.026$ for 8654 independent reflections. III: $\text{RhO}_4\text{N}_3\text{C}_{16}\text{H}_{26}$, monoclinic, $P2_1/c$, $a = 8.479$ (2) Å, $b = 29.049$ (5) Å, $c = 9.040$ (2) Å, $\beta = 117.44$ (2)°, $D(\text{calcd}) = 1.53$ g cm^{-3} , $Z = 4$, $R(F_o) = 0.036$ for 2446 independent reflections. The geometry of the $\text{Rh}(\text{DH})_2$ moiety, almost identical in all three complexes, is characterized by mean $\text{Rh}-\text{N}$ equatorial distances ranging from 1.973 (7) (I) to 1.981 (5) Å (II) and mean $\text{O}\cdots\text{O}$ distances in the range from 2.65 (1) (I) to 2.68 (1) Å (III). Comparison with alkylcobaloximes indicates an increase of ≈ 0.2 Å for the latter and ≈ 0.1 Å for the former. The axial $\text{Rh}-\text{C}$ and $\text{Rh}-\text{N}$ distances lengthen with the increasing bulk and the σ -donating ability of the alkyl group, respectively. The $\text{Rh}-\text{C}$ distances range from 2.063 (5) (I) to 2.107 (5) Å (III) and the $\text{Rh}-\text{N}$ (axial) distances from 2.220 (3) (I) to 2.230 (4) Å (III). The trend of rate constants for the pyridine displacement is that expected on the basis of the increasing σ -donor power of the alkyl group. Comparison with the analogous cobaloximes indicates that the structural parameters, mainly determined by the electronic factors of the alkyl group, follow a similar trend both in rhodioximes and cobaloximes. Furthermore, the smoother variation of the $\text{Rh}-\text{R}$ bond lengths with the increasing bulk of R with respect to that in alkylcobaloximes suggest that the coordination of ligands around the Rh center is less "hindered" than that around Co .

Introduction

The study of simple models of the B₁₂ coenzyme (5'-deoxyadenosylcobalamin), such as the so-called cobaloximes, $\text{LCo}(\text{DH})_2\text{R}$, where L = neutral ligand, DH = monoanion of dimethylglyoxime, and R = alkyl group, has furnished a significant amount of data^{1,2} that have provided a foundation for understanding the behavior of the more complex cobalamins.³ Structural data showed a lengthening of the $\text{Co}-\text{C}$ bond of about 0.2 Å in complexes with R = adamantyl with respect to those with R = methyl. Correspondently, the bending angle, α , between the chemically equivalent halves of the equatorial moiety, $(\text{DH})_2$, increases toward the L ligand. These observations gave support to the "trigger" mechanism suggested for the homolytic cleavage of the $\text{Co}-\text{C}$ bond in coenzyme B₁₂.^{1,2,4} However, with a few exceptions, such as $\text{Me}_3\text{BzmCo}(\text{DH})_2\text{CH}(\text{CN})\text{CH}_2\text{CN}$ ⁵ (Me_3Bzm = 1,5,6-trimethylbenzimidazole), and $\text{pyCo}(\text{DH})_2\text{CH}(\text{Me})\text{CN}$,⁶ the complexes so far studied contained either bulky alkyl groups that are also good σ -donor or good electron-withdrawing groups with a relatively small bulk. Therefore, it may be argued that the electronic nature of R could play a role in determining the $\text{Co}-\text{C}$ bond length, which could increase because of the increasing σ -donor power of the alkyl group. A preliminary evidence that the electronic influence is at least of second order with respect to steric influence was furnished by the $\text{Co}-\text{CH}(\text{CN})\text{CH}_2\text{CN}$ bond length of 2.061 (3) Å, which is closer to the $\text{Co}-\text{CHMe}_2$ distance of 2.076 (3) Å than that of 1.989 (2) Å found for the $\text{Co}-\text{Me}$ in the series $\text{Me}_3\text{BzmCo}(\text{DH})_2\text{R}$.⁵ Further evidences could be derived from the study of the corresponding Rh derivatives, $\text{LRh}(\text{DH})_2\text{R}$, the so-called rhodioximes. In fact, the axial distances in the latter should be expected longer than those in cobaloximes,

owing to the larger ionic radius of $\text{Rh}(\text{III})$. Consequently, the steric interaction between the R and $(\text{DH})_2$ ligand should be partially relieved, as shown by the comparison of the $\text{PPh}_3\text{M}(\text{DH})_2\text{Cl}$ structures, where $\text{M} = \text{Rh}^{\text{I}}$ and Co .⁸ The $\text{Co}-\text{Cl}$ and $\text{Rh}-\text{Cl}$ bond lengths are 2.277 (4) and 2.381 (1) Å, respectively, suggesting a difference of about 0.1 Å in the ionic radii. On the contrary, the $\text{Co}-\text{P}$ (2.327 (4) Å) and $\text{Rh}-\text{P}$ (2.327 (1) Å) distances are equal within experimental error. This apparent discrepancy has been attributed to the strong steric interaction of the bulky phosphine with $(\text{DH})_2$ in the Co derivative,⁸ which is relieved to a large extent in the Rh analogue. Therefore, it seemed of worth to extend these studies to complexes of organorhodium series. The syntheses, crystal structures and kinetics of the $\text{pyRh}(\text{DH})_2\text{R}$ with $\text{R} = \text{Me}$ (I), Et (II), and *i*-Pr (III) are reported and discussed.

Experimental Section

Synthesis. Methylene chloride, used as solvent for kinetic measurements, and all other materials were reagent grade and were used without further purification. The organorhodium complexes $\text{pyRh}(\text{DH})_2\text{R}$, where $\text{R} = \text{Me}$, Et , *n*-Pr, and *i*-Pr, were obtained from the corresponding $\text{XRh}(\text{DH})_2\text{R}$ derivatives ($\text{X} = \text{Br}$ or I), prepared by the procedure previously described⁹ from $\text{Cl}_2\text{Rh}(\text{DH})(\text{DH}_2)$ and the appropriate alkylating agent in the presence of the NaBH_4 . The pyridine derivatives were obtained by dissolving 0.2 g of $\text{XRh}(\text{DH})_2\text{R}$ in the least volume of methanol and by adding a stoichiometric amount of AgNO_3 . The resulting precipitate of AgX was filtered off and an excess of pyridine was added to the solution. The volume was reduced by evaporation until precipitation began. Crystals of the desired products were collected by filtration. The solids were recrystallized by the following procedure: complexes were dissolved in CH_2Cl_2 and any undissolved material was removed by filtration. *n*-Pentane was added slowly to form a layer above the CH_2Cl_2 solution. The solution was allowed to stand until diffusion between the two layers was complete. Yellow crystals, which precipitated from a CH_2Cl_2 -*n*-pentane mixture were collected by filtration and dried in the air. The results of elemental analyses are given as supplementary material.

Kinetic Measurements. Ligand substitution reactions were monitored spectrophotometrically in the range 350–450 nm by using a HiTech SF3 series stopped-flow instrument. Kinetic runs were carried out in the noncoordinating solvent CH_2Cl_2 at 25 °C, with an excess of entering

- Randaccio, L.; Bresciani Pahor, N.; Zangrando, E.; Marzilli, L. G. *Chem. Soc. Rev.* **1989**, 16, 229.
- Bresciani Pahor, N.; Forcolin, M.; Marzilli, L. G.; Randaccio, L.; Summers, M. F.; Toscano, P. J. *Coord. Chem. Rev.* **1985**, 63, 1.
- Kim, S. H.; Chen, H. L.; Feilchenfeld, N.; Halpern, J. *J. Am. Chem. Soc.* **1988**, 110, 3120. Hay, B. P.; Finke, R. G. *J. Am. Chem. Soc.* **1987**, 109, 8012. Pratt, J. M. *Chem. Soc. Rev.* **1985**, 161. Golding, B. T. *J. R. Neth. Chem. Soc.* **1987**, 106, 342.
- Halpern, J. *Science (Washington, D.C.)* **1985**, 227, 869. Pett, V. B.; Liebman, M. N.; Murray-Rust, P.; Prasad, K.; Glusker, J. P. *J. Am. Chem. Soc.* **1987**, 109, 3207.
- Unpublished results from this laboratory.
- Ohashi, Y.; Yanagi, K.; Kurihara, T.; Sasada, Y.; Ohgo, Y. *J. Am. Chem. Soc.* **1982**, 104, 6353.

- Cotton, F. A.; Norman, J. G., Jr. *J. Am. Chem. Soc.* **1971**, 93, 80.
- Brückner, S.; Randaccio, L. *J. Chem. Soc., Dalton Trans.* **1974**, 1017.
- Dreos Garlatti, R.; Tazher, G.; Costa, G. *Inorg. Chim. Acta* **1986**, 121, 27.

Table I. Crystallographic Data for Compounds I–III (pyRh(DH)₂R)^a

	I	II	III
R	Me	Et	<i>i</i> -Pr
formula	RhO ₄ N ₅ C ₁₄ H ₂₂ ^{1/4} /4H ₂ O	RhO ₄ N ₅ C ₁₅ H ₂₄	RhO ₄ N ₅ C ₁₆ H ₂₆
fw	431.8	441.3	455.3
<i>a</i> , Å	16.400 (3)	9.140 (3)	8.479 (3)
<i>b</i> , Å	11.963 (3)	12.120 (4)	29.049 (5)
<i>c</i> , Å	9.329 (2)	16.744 (6)	9.040 (2)
α, deg		98.53 (2)	
β, deg		90.30 (2)	117.44 (2)
γ, deg		92.09 (2)	
<i>V</i> , Å ³	1830.3 (7)	1833 (1)	1976 (1)
<i>Z</i>	4	4	4
space group	<i>P</i> 2 ₁ 2 ₁ 2 (No. 18)	<i>P</i> $\bar{1}$ (No. 2)	<i>P</i> 2 ₁ / <i>c</i> (No. 14)
<i>D</i> (calcd), g cm ⁻³	1.55	1.60	1.53
<i>D</i> (mesd), g cm ⁻³	1.56	1.59	1.55
μ(Mo Kα), cm ⁻¹	9.4	9.4	8.8
no. of measd reflns	3027	10 964	10 044 ^b
no. of indep reflns [<i>I</i> ≥ 3σ(<i>I</i>)]	2610	8654	2446
<i>R</i> (<i>F</i> _o)	0.031	0.026	0.036
<i>R</i> _w (<i>F</i> _o)	0.041	0.028	0.045

^aAll data were collected at 18° C by using graphite-monochromated Mo Kα radiation (λ = 0.7107 Å). ^bData collected by using a triclinic space group.

ligand L', with concentrations ranging from 4 × 10⁻³ to 5 × 10⁻¹ M. Solutions of complex from 2 × 10⁻⁴ to 4 × 10⁻⁴ M were used. The rate expression is consistent with a pseudo-first-order reaction, and the *k*_{obs} values were obtained from a linear plot of ln(*A* - *A*_∞) versus time, where *A* is the absorbance at time *t* and *A*_∞ is the final absorbance.

Crystal Data. Cell dimensions, determined preliminarily from Weissenberg and precession photographs, were refined from 25 reflections lying in the θ range 13–18° on an Enraf-Nonius CAD4 single-crystal diffractometer. The same instrument was then used to collect intensity data by the ω/2θ scan technique, by using graphite-monochromated Mo Kα radiation (λ = 0.7107 Å). Intensities of three standard reflections were measured during data collections and did not show any decay throughout the data recording. Reflections with *I* ≥ 3σ(*I*) were corrected for Lorentz and polarization effects. Empirical absorbance corrections based on ψ-scan data were applied to the reflection intensities. Anomalous dispersion and secondary extinction correction were applied to compound II. The crystal data and data collection are summarized in Table I.

Solution and Refinement of the Structures. All the structures were solved by conventional Patterson and Fourier methods. After anisotropic refinements, the calculated positions of hydrogen atoms all occurred in positive electron density regions. In I a water molecule of crystallization (OW), with half occupancy factor, was found. The occupancy was fixed on the basis of the electron peak density on the Fourier map. Final full-matrix anisotropic least-squares refinements, with the fixed contribution of hydrogen atoms (*B* = 5.0 Å² for I and III, and *B* = 1.3*B*_{eq} of the atom they are attached for II), converged to final *R*(*F*_o) and *R*_w(*F*_o) values reported in Table I. The final weighting scheme was *w* = 1/(σ²(*F*) + (0.02*F*)² + 1.0) for I and III and unitary for II, chosen so as to maintain *w*(|*F*_o| - |*F*_c|)² essentially constant over all ranges of |*F*_o| and (sin θ)/λ. Final non-hydrogen positional parameters and *B*_{eq} (Å²) are given in Tables II–IV. Atomic scattering factors, anomalous dispersion terms, and programs were taken from the Enraf-Nonius SDP package.¹⁰ Hydrogen atom coordinates, anisotropic thermal parameters, tables of all bond lengths and angles, and lists of calculated and observed structure factors are available as supplementary material.

Results

Rate Measurement. It has been shown that ligand exchange reactions of LRh(DH)₂Me in CH₂Cl₂,¹¹ as the corresponding reactions of the analogous Co(III) complexes,^{2,12} proceed through a dissociative mechanism, D

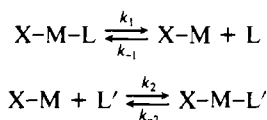

where the rate-determining step is the dissociation of L from the

Table II. Atomic Positional Parameters and Their Esd's for Compound I

atom	x	y	z	<i>B</i> , Å ²
Rh	0.16377 (2)	0.22792 (2)	0.23032 (3)	2.909 (4)
O(1)	0.1587 (2)	0.1984 (3)	-0.0809 (3)	4.87 (7)
O(2)	0.1440 (2)	0.4372 (3)	0.3793 (4)	5.62 (8)
O(3)	0.1509 (2)	0.2545 (4)	0.5412 (3)	5.41 (8)
O(4)	0.1781 (2)	0.0188 (3)	0.0783 (4)	4.95 (7)
N(1)	0.1551 (2)	0.2745 (3)	0.0279 (4)	3.84 (7)
N(2)	0.1462 (2)	0.3908 (3)	0.2507 (5)	4.31 (8)
N(3)	0.1614 (2)	0.1786 (4)	0.4307 (4)	3.93 (7)
N(4)	0.1732 (2)	0.0641 (3)	0.2063 (4)	3.59 (7)
N(5)	0.2983 (2)	0.2486 (3)	0.2299 (4)	3.27 (6)
C(1)	0.1287 (4)	0.4264 (5)	-0.1445 (7)	6.0 (1)
C(2)	0.1404 (3)	0.3979 (4)	0.0020 (6)	4.5 (1)
C(3)	0.1378 (3)	0.4475 (4)	0.1302 (7)	4.9 (1)
C(4)	0.1248 (4)	0.5713 (5)	0.129 (1)	7.4 (2)
C(5)	0.1562 (4)	0.0237 (6)	0.6029 (6)	6.6 (1)
C(6)	0.1631 (3)	0.0720 (4)	0.4555 (5)	4.34 (9)
C(7)	0.1710 (3)	0.0046 (4)	0.3249 (5)	4.10 (8)
C(8)	0.1722 (3)	-0.1197 (4)	0.3257 (8)	6.0 (1)
C(9)	0.0388 (3)	0.2076 (4)	0.2330 (6)	4.7 (1)
C(10)	0.3465 (3)	0.1953 (4)	0.3215 (6)	4.37 (9)
C(11)	0.4299 (3)	0.2090 (5)	0.3261 (7)	5.8 (1)
C(12)	0.4657 (3)	0.2792 (5)	0.2279 (7)	6.4 (1)
C(13)	0.4168 (3)	0.3359 (5)	0.1301 (7)	5.7 (1)
C(14)	0.3345 (3)	0.3169 (4)	0.1346 (5)	4.29 (8)
OW	0.000	0.500	0.504 (1)	4.6 (2) ^b

^aValues for anisotropically refined atoms are given in the form of the isotropic equivalent displacement parameter defined as *B*_{eq} = (4/3)Σ_{i,j}μ_iμ_jβ_iβ_j(*i,j*). ^bIsotropically refined.

complex (M represents the M(DH)₂ moiety and X the nonlabile axial group). The related expression of *k*_{obs}

$$k_{\text{obs}} = \frac{k_1 + k_2 k_{-1} [\text{L}]/k_2 [\text{L}']}{1 + k_{-1} [\text{L}]/k_2 [\text{L}']}$$

reduces to

$$k_{\text{obs}} = k_1 \quad (1)$$

in absence of added leaving ligand ([L] = 0), so that the reaction rate becomes independent of both concentration and chemical identity of L'. The *k*_{obs} values found for the substitution reactions

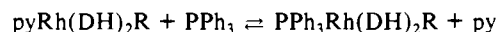

for R = Me, Et, *n*-Pr, and *i*-Pr, are independent of [PPh₃] in the examined concentrations range, suggesting that a D mechanism is operative also in the present case. Thus, eq 1 accounts for the experimental results, and the *k*₁ values are first-order dissociation rate constants.

(10) Frenz, B. A. *Enraf-Nonius Structure Determination Package*, Version 18; Enraf-Nonius: Delft, The Netherlands.

(11) Dreo Garlatti, R.; Tauzher, G. *Polyhedron*, in press.

(12) Stewart, R. C.; Marzilli, L. G. *J. Am. Chem. Soc.* **1978**, *100*, 817.

Table III. Atomic Positional Parameters and Their Esd's for Compound II

molecule A					molecule B				
atom	x	y	z	B, Å ²	atom	x	y	z	B, Å ²
Rh(A)	0.22011 (2)	0.28356 (1)	0.09021 (1)	2.390 (3)	Rh(B)	0.24199 (2)	0.72725 (2)	0.39023 (1)	3.061 (3)
O(1A)	-0.0568 (2)	0.2833 (2)	0.0036 (1)	4.40 (4)	O(1B)	0.4172 (2)	0.9277 (2)	0.3767 (1)	5.29 (5)
O(2A)	0.3109 (2)	0.1093 (2)	0.1801 (1)	4.57 (4)	O(2B)	-0.0768 (2)	0.7141 (2)	0.4021 (2)	5.85 (6)
O(3A)	0.4932 (2)	0.2800 (2)	0.1812 (1)	4.52 (4)	O(3B)	0.0656 (3)	0.5262 (2)	0.4001 (2)	5.88 (5)
O(4A)	0.1341 (2)	0.4675 (1)	0.0071 (1)	3.72 (4)	O(4B)	0.5608 (2)	0.7384 (2)	0.3760 (2)	6.34 (6)
N(1A)	0.0232 (2)	0.2277 (2)	0.0497 (1)	3.16 (4)	N(1B)	0.2816 (3)	0.8879 (2)	0.3834 (1)	3.80 (4)
N(2A)	0.2022 (2)	0.1419 (2)	0.1350 (1)	3.31 (4)	N(2B)	0.0426 (2)	0.7837 (2)	0.3960 (1)	3.93 (5)
N(3A)	0.4127 (2)	0.3417 (2)	0.1377 (1)	3.05 (4)	N(3B)	0.2011 (3)	0.5652 (2)	0.3938 (1)	4.28 (5)
N(4A)	0.2366 (2)	0.4318 (2)	0.0539 (1)	2.63 (3)	N(4B)	0.4410 (3)	0.6693 (2)	0.3833 (1)	4.36 (5)
N(5A)	0.3185 (2)	0.2066 (2)	-0.0256 (1)	3.10 (4)	N(5B)	0.2574 (2)	0.7595 (2)	0.5233 (1)	3.37 (4)
C(1A)	-0.1804 (3)	0.0919 (3)	0.0563 (2)	5.75 (7)	C(1B)	0.1823 (5)	1.0735 (3)	0.3834 (3)	6.9 (1)
C(2A)	-0.0264 (3)	0.1363 (2)	0.0746 (2)	3.69 (5)	C(2B)	0.1684 (4)	0.9500 (2)	0.3863 (2)	4.33 (6)
C(3A)	0.0778 (3)	0.0865 (2)	0.1237 (2)	3.81 (5)	C(3B)	0.0285 (3)	0.8888 (3)	0.3933 (2)	4.37 (6)
C(4A)	0.0451 (5)	-0.0191 (3)	0.1581 (2)	6.11 (8)	C(4B)	-0.1179 (4)	0.9420 (3)	0.3947 (2)	6.69 (9)
C(5A)	0.5944 (3)	0.4987 (3)	0.1605 (2)	4.73 (6)	C(5B)	0.3033 (6)	0.3800 (3)	0.3976 (3)	8.2 (1)
C(6A)	0.4538 (2)	0.4421 (2)	0.1272 (1)	3.03 (4)	C(6B)	0.3153 (4)	0.5037 (3)	0.3928 (2)	5.03 (7)
C(7A)	0.3508 (2)	0.4954 (2)	0.0790 (1)	2.74 (4)	C(7B)	0.4534 (4)	0.5639 (3)	0.3865 (2)	5.10 (6)
C(8A)	0.3741 (3)	0.6117 (2)	0.0604 (2)	3.81 (5)	C(8B)	0.5995 (4)	0.5095 (4)	0.3830 (3)	8.22 (9)
C(9A)	0.1254 (3)	0.3602 (2)	0.1956 (2)	3.36 (5)	C(9B)	0.2355 (4)	0.6952 (3)	0.2647 (2)	4.37 (6)
C(10A)	-0.0209 (3)	0.4110 (3)	0.1860 (2)	4.76 (6)	C(10B)	0.0917 (4)	0.7062 (3)	0.2236 (2)	5.88 (8)
C(11A)	0.2637 (3)	0.2256 (2)	-0.0958 (2)	3.97 (5)	C(11B)	0.3617 (3)	0.8282 (2)	0.5622 (2)	4.07 (6)
C(12A)	0.3242 (4)	0.1830 (3)	-0.1698 (2)	5.14 (7)	C(12B)	0.3747 (4)	0.8481 (3)	0.6451 (2)	5.04 (7)
C(13A)	0.4445 (4)	0.1181 (3)	-0.1700 (2)	5.65 (7)	C(13B)	0.2765 (4)	0.7966 (3)	0.6902 (2)	5.48 (7)
C(14A)	0.5008 (3)	0.0984 (2)	-0.0979 (2)	4.99 (7)	C(14B)	0.1670 (4)	0.7265 (3)	0.6513 (2)	5.22 (7)
C(15A)	0.4362 (3)	0.1439 (2)	-0.0273 (2)	3.88 (5)	C(15B)	0.1617 (3)	0.7093 (3)	0.5679 (2)	4.16 (6)

Table IV. Atomic Positional Parameters and Their Esd's for Compound III

atom	x	y	z	B, Å ²
Rh	0.30354 (4)	0.13172 (1)	0.13966 (4)	3.099 (7)
O(1)	0.3058 (5)	0.1694 (2)	0.4392 (4)	6.4 (1)
O(2)	0.0646 (4)	0.0612 (1)	-0.0719 (4)	5.1 (1)
O(3)	0.3092 (4)	0.0935 (1)	-0.1572 (4)	5.2 (1)
O(4)	0.5476 (5)	0.2016 (1)	0.3549 (5)	6.3 (1)
N(1)	0.2246 (5)	0.1397 (2)	0.3121 (5)	4.4 (1)
N(2)	0.1052 (4)	0.0872 (1)	0.0643 (4)	3.64 (9)
N(3)	0.3818 (5)	0.1251 (1)	-0.0342 (4)	3.81 (9)
N(4)	0.4999 (5)	0.1771 (1)	0.2140 (5)	4.3 (1)
N(5)	0.4932 (4)	0.0772 (1)	0.2941 (4)	3.59 (9)
C(1)	0.0144 (8)	0.1170 (3)	0.4182 (7)	7.7 (2)
C(2)	0.0900 (6)	0.1148 (2)	0.2958 (6)	4.9 (1)
C(3)	0.0218 (6)	0.0839 (2)	0.1518 (6)	4.6 (1)
C(4)	-0.1295 (7)	0.0519 (3)	0.1114 (8)	7.1 (2)
C(5)	0.5748 (7)	0.1524 (3)	-0.1531 (7)	7.2 (2)
C(6)	0.5101 (6)	0.1523 (2)	-0.0241 (6)	4.7 (1)
C(7)	0.5775 (6)	0.1826 (2)	0.1210 (6)	4.8 (1)
C(8)	0.7211 (8)	0.2172 (3)	0.1576 (9)	7.3 (2)
C(9)	0.1105 (7)	0.1811 (2)	-0.0019 (6)	5.0 (1)
C(10)	0.0334 (8)	0.1753 (2)	-0.1854 (7)	7.0 (2)
C(11)	0.159 (1)	0.2292 (2)	0.055 (1)	8.3 (2)
C(12)	0.4914 (6)	0.0353 (2)	0.2327 (6)	4.7 (1)
C(13)	0.6020 (7)	0.0006 (2)	0.3272 (7)	5.8 (2)
C(14)	0.7154 (7)	0.0081 (2)	0.4895 (7)	6.4 (2)
C(15)	0.7211 (7)	0.0509 (2)	0.5570 (7)	5.9 (2)
C(16)	0.6075 (6)	0.0844 (2)	0.4554 (6)	4.8 (1)

Structural Studies. The rhodium atom has a distorted octahedral coordination in all the three rhodoximes, as shown by the ORTEP drawings for non-hydrogen atoms depicted in Figures 1-3, together with the atom numbering scheme. For II, the numbering scheme refers to one of the two crystallographically independent molecules, A, and applies also to molecule B. The chemically equivalent halves of the equatorial ligand are approximately planar, and their mean planes bend toward the alkyl group, as indicated by the positive values of the corresponding dihedral angle, α , reported in Table V. The displacements, d , of the Rh atom out of the mean plane passing through the four equatorial N-donor atoms is toward pyridine (Table V). In previous papers, regarding LCo(DH)₂R complexes,^{1,2} it has been assumed that bendings toward the alkyl group and displacements toward the neutral ligand are denoted by positive values of α and d , respectively.

The orientations of the planar L ligand in I-III, with respect to the equatorial moiety, are represented by the values of the

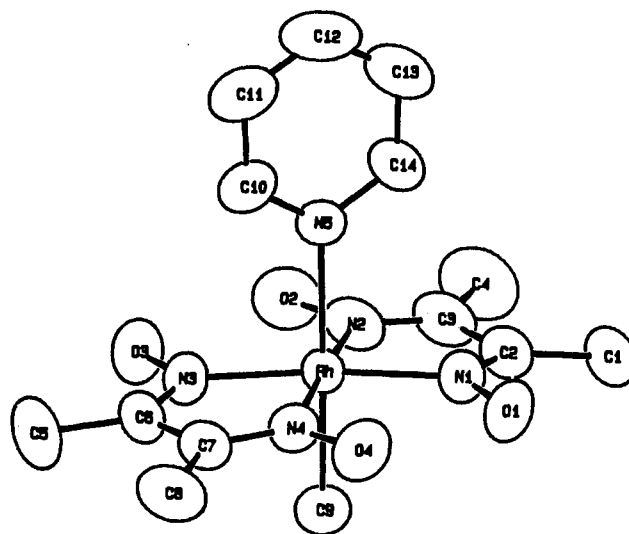

Figure 1. ORTEP drawing (50% probability thermal ellipsoids) and labeling scheme for non-hydrogen atoms of I.

torsional angles C-N(5)-Rh-N(3) (Figure 4), which indicate that the py plane orientation in I differs by a rotation of about 90° from those in II and III. In all the pyCo(DH)₂R complexes so far structurally characterized, the py orientation was found to be always very close to that found in II and III. Therefore, compound I represents the first example with py in such an orientation and this has implications (vide infra) in determining the axial metal-N distance.¹

Discussion

Some geometrical features of I-III are compared with those of the corresponding Co(DH)₂ derivatives in Table V.

The large value of α in I, as compared with that in the cobaloxime analogue, is possibly related to the different orientation of py (Figure 4a). A similar orientation has been already observed in cobaloximes having as neutral ligand the less bulky 1-methylimidazole¹ (1MeImd) and has been ascribed to crystal packing forces, which may sometimes stabilize one conformation with respect to the other. In {pyCo[(DO)(DOH)pn]R}PF₆ complexes,¹³ where (DO)(DOH)pn = N²,N^{2'}-propanediylbis(2,3-bu-

(13) Parker, W. O., Jr.; Bresciani Pahor, N.; Zangrando, E.; Randaccio, L.; Marzilli, L. G. *Inorg. Chem.* **1985**, *24*, 3908.

Table V. $\log k_1$, Bond Length (\AA), and Bond Angles (deg) of the Axial Fragment, py-M-R , of I-III ($\text{M} = \text{Rh}$) and the Corresponding Values for the Analogous Cobaloximes ($\text{M} = \text{Co}$) and the Displacement of M out of the Four N Equatorial Donors, d (\AA), and the Bending Angles, α (deg)

R	$\log k_1$	M-N	M-C	N-M-C	M-C α -C	C α -C	d	α
$\text{M} = \text{Rh}^a$								
Me	-1.48	2.220 (3)	2.063 (5)	179.4 (2)			+0.08	+10.8
Et(A)	-0.24	2.232 (2)	2.077 (2)	177.70 (9)	116.2 (2)	1.510 (4)	+0.07	+13.0
Et(B)		2.207 (2)	2.080 (3)	177.9 (1)	117.5 (2)	1.500 (4)	+0.02	+0.5
<i>n</i> -Pr	-0.27							
<i>i</i> -Pr	0.80	2.230 (4)	2.107 (5)	175.8 (2)	114.9 (6) ^b	1.484 (9) ^b	+0.02	+4.3
$\text{M} = \text{Co}^{c,d}$								
Me	-1.39	2.068 (3)	1.998 (5)	178.0 (2)			+0.04	+3.2
Et ^e	-0.02	2.081 (3)	2.035 (5)	177.1 (2)	117.8 (4)	1.519 (8)	+0.05	+9.1
<i>n</i> -Pr	0.08							
<i>i</i> -Pr	1.43	2.099 (2)	2.085 (3)	174.1 (2)	114.2 (2) ^b	1.507 (4) ^b	+0.02	+4.0

^a Present work. ^b Mean values. ^c The neutral ligand for $\log k_1$ in cobaloximes is 4CN-py; for py analogues, the $\log k_1$ values are available only for $\text{R} = \text{Me}$ (-2.10) and for $\text{R} = i\text{-Pr}$ (0.47).² ^d Reference 2. ^e The structural data refer to $4\text{N}(\text{H})=\text{C}(\text{OMe})\text{-pyCo}(\text{DH})_2\text{Et}$.

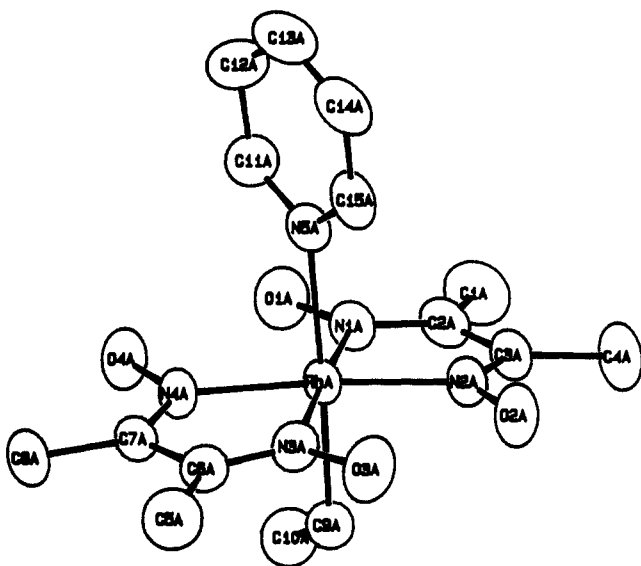

Figure 2. ORTEP drawing (50% probability thermal ellipsoids) and labeling scheme for non-hydrogen atoms of molecule A of II. The same scheme applies also for B.

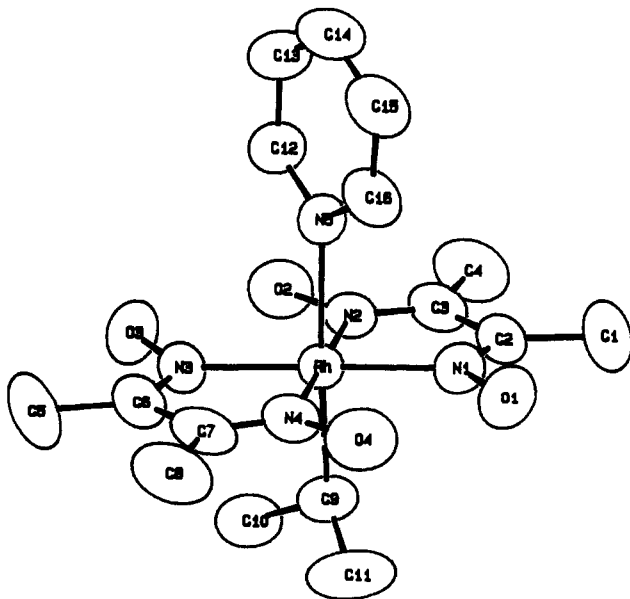

Figure 3. ORTEP drawing (50% probability thermal ellipsoids) and labeling scheme for non-hydrogen atoms of III.

tanedione 2-imine 3-oxime), the py ligand is always oriented in a way similar to that in I with values of α larger than those in corresponding cobaloximes.

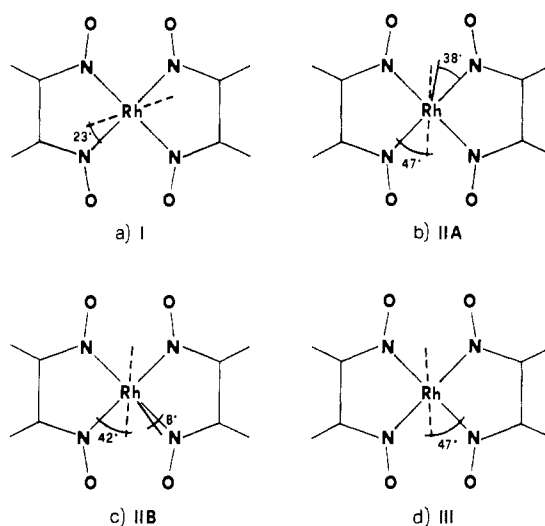

Figure 4. Orientation of the py plane (broken line) with respect to the equatorial moiety $\text{Rh}(\text{DH})_2$ in I-III. The orientations of the ethyl group (full line) in II is also indicated.

It is also interesting to note the significant difference in the orientation of the ethyl group in the two crystallographically independent molecules of II (Figure 4). The usual orientation, reported for several ethylcobaloximes¹⁴ with the $\text{CH}_2\text{-CH}_3$ bond nearly above one of the equatorial coordination bonds, is found in molecule B [$\text{N}(2)\text{-Rh-C}(9)\text{-C}(10) = -8.5(3)^\circ$]. In contrast, in molecule A, the $\text{CH}_2\text{-CH}_3$ bond crosses approximately the oxime bridge $\text{O}(1)\cdots\text{O}(4)$ (Figure 4), with torsional angles $\text{C}(10)\text{-C}(9)\text{-Rh-N}(1)$ and $\text{C}(10)\text{-C}(9)\text{-Rh-N}(4)$ of $-37.6(2)$ and $+64.8(2)^\circ$, respectively (Figure 4b,c). The orientation in molecule A corresponds to distortions larger than those found in molecule B, as indicated by the comparison of α and d values and of the $\text{Rh-N}(5)$ distances (Table V), but does not affect the Rh-C bond lengths and the Rh-C-C angles. Furthermore, a significant difference between the $\text{O}(1)\cdots\text{O}(4)$ (2.777(3) \AA) and $\text{O}(2)\cdots\text{O}(3)$ (2.607(3) \AA) distances in molecule A is found, the latter being shorter and the former longer than those observed in molecule B as well as in I and III. These observations suggest that the above differences between molecules A and B, as well as the $\text{Rh-N}(5)$ bond lengths (see below), may be due, in molecule A, to the steric interactions involving the terminal ethyl hydrogens and the $\text{O}(1)\cdots\text{O}(4)$ oxime bridge H, on one side, and the H atom attached to C(11) of py, on the other side. The nonequivalence between the $\text{O}\cdots\text{O}$ oxime bridges was observed in $\text{PPh}_3\text{Rh}(\text{DH})_2\text{Cl}$ (2.709(6) and 2.618(6) \AA)⁷ and in $\text{SbPh}_3\text{Rh}(\text{DH})_2\text{Cl}$ (2.70(1) and 2.61(1) \AA).¹⁵ Such a nonequivalence of the oxime bridge is similar,

(14) Parker, W. O., Jr.; Zangrando, E.; Bresciani Pahor, N.; Marzilli, P. A.; Randaccio, L.; Marzilli, L. G. *Inorg. Chem.* **1988**, *27*, 2170 and references therein.

Table VI. Mean Values of the Chemically Equivalent Bond Lengths (Å) and Angles (deg) Involving the Metal Atom in I-III, with Their Esd's in Parentheses^a

	M-N	N-O	C-N	C-C	C-Me	O...C	M-N-O	M-N-C	N(1)-M-N(2)	N(1)-M-N(4)
I	1.973 (7)	1.35 (3)	1.31 (1)	1.457 (9)	1.492 (4)	2.65 (1)	120.9 (4)	116.8 (8)	78.9 (2)	101.0 (6)
IIA	1.981 (5)	1.344 (9)	1.301 (4)	1.460 (3)	1.500 (2)	<i>b</i>	121.5 (6)	116.7 (5)	78.8 (3)	<i>b</i>
IIB	1.98 (1)	1.35 (2)	1.298 (3)	1.46 (1)	1.508 (3)	2.67 (1)	120.9 (3)	116.8 (6)	78.7 (2)	101.4 (3)
III	1.978 (4)	1.348 (3)	1.30 (1)	1.463 (2)	1.50 (1)	2.68 (1)	121.0 (7)	117.1 (4)	78.5 (2)	101.6 (5)
Co(DH) ₂	1.8901 (9)	1.3492 (9)	1.301 (1)	1.462 (3)	1.501 (1)	2.487 (2)	122.63 (7)	116.6 (7)	81.38 (5)	98.57 (8)

^aThe corresponding mean values for cobaloximes² are reported for comparison. Angles involving side methyl groups are not given. ^bSee text.

although less enhanced, than that found in [PPh₃Rh(DH)(DH₂)Cl]Cl,¹⁶ where the protonated "oxime bridge" has an HO...OH distance of 3.77 (1) Å, while the opposite O...HO distance is shortened to 2.42 (1) Å. The corresponding N-Rh-N angles have values of 113.2 (3) and 95.5 (4)°, respectively. Since these geometrical features have never been observed in more than 100 cobaloximes,^{1,2} it seems likely that the easier bridge protonation in rhodoximes¹⁶ than in cobaloximes¹⁷ is related to the greater "softness" of the bridge in the former.

The bond lengths and angles of the equatorial moiety, Rh(DH)₂, are similar in all the complexes and the mean values for those chemically equivalent are given in Table VI. Within the experimental errors, these data do not differ from those previously reported for PPh₃Rh(DH)₂Cl.⁷ The comparison with cobaloximes² (Table VI) indicates that the largest differences are observed in the equatorial Rh-N bond lengths, about 0.1 Å longer than the corresponding Co-N bond lengths and for the O...O distances. Slight variations of a few degree in the Rh-N-O and Rh-N-C angles with respect to those observed in cobaloximes are probably due to the need of optimizing the Rh-N distances. The other bond lengths and angles do not change significantly with respect to those of the Co(DH)₂ species (Table VI).

The Rh-C distances increase by ≈0.04 Å in going from Me to *i*-Pr. The corresponding increase in cobaloximes is significantly greater, being ≈0.08 Å, as shown in Table V. Such a difference suggests a significant relief of the steric interaction between R and the equatorial moiety in rhodoximes, ascribable to the ionic radius of Rh(III) being larger than that of Co(III). This result supports the widely accepted hypothesis¹ that the lengthening of the metal-carbon bond mainly follows the increase in bulk of the alkyl group (steric cis influence) and that the electronic effects should play a minor role, if any, in determining this bond length.

The usual trend of the axial Co-N distances in cobaloximes¹ is illustrated in Table V: they increase in the order Me < Et < *i*-Pr, following the σ-donating ability of the alkyl group. Corresponding data for rhodoximes (Table V) apparently do not follow this trend. However, in cobaloximes with L = imidazole ligand,¹⁸ the planar ligand orientation of the kind found in I (Figure 4a), corresponds to an increase of ≈0.04 Å of the Co-N axial distance with respect to the usual orientation observed in II and III. If this applies also to rhodoximes, in I the Rh-N(axial) distance expected for the usual orientation of py should be 2.18 Å. Furthermore, preliminary structural results for pyRh(DH)₂(*n*-Pr)⁵ indicate a Rh-N(axial) bond length of 2.188 (5) Å, close to that obtained for molecule B of II, as expected on the basis of the σ-donor powers of Et and *n*-Pr groups for the usual Et orientation (see above). Therefore, the Rh-N distance trend in alkylrhodoximes is altered by a conformational freedom of the axial ligands larger than that in alkylcobaloximes.

However, the trend of log *k*₁ for the displacement reaction of L is that expected on the basis of the increasing σ-donor power of the alkyl group (Table V), as already observed in the 1MeImd alkylcobaloximes.¹⁹ Since it has been found that the rate constants for the pyridine-alkylcobaloximes are nearly 1 order of magnitude less than those of the analogous 4-CN-pyridine,¹ it may be concluded that pyridine alkylrhodoximes have log *k*₁'s about 0.5 unit higher than those of the corresponding cobaloximes.

Acknowledgment. We are grateful to CNR (Rome) and to MPI (Rome) for financial support.

Supplementary Material Available: Tables of elemental analyses for pyRh(DH)₂R and full crystallographic data, anisotropic thermal parameters, hydrogen atom coordinates, and complete bond lengths and bond angles for I-III (17 pages); tables of structure factors for compounds I-III (29 pages). Ordering information is given on any current masthead page.

- (15) Chiesi Villa, A.; Gaetani Manfredotti, A.; Guastini, C. *Cryst. Struct. Commun.* **1973**, *2*, 129.
 (16) Chiesi Villa, A.; Gaetani Manfredotti, A.; Guastini, C. *Cryst. Struct. Commun.* **1973**, *2*, 133.
 (17) Gulsch, R. J.; Brown, T. L. *Inorg. Chem.* **1974**, *13*, 959.

- (18) Bresciani Pahor, N.; Attia, W. M.; Geremia, S.; Randaccio, L.; Lopez, C. *Acta Crystallogr.* **1989**, *C45*, 561.
 (19) Bresciani Pahor, N.; Geremia, S.; Lopez, C.; Randaccio, L.; Zangrando, E. *Inorg. Chem.* **1990**, *29*, 1043.